



# Technical Application Guide for UP-SHINE LED Spotlight

UP-SP92MR16-9W

# Introduction



LED Spotlight adopts COB LED, with high brightness and slight light decay. Excellent heat dissipation with aluminum heatsink and good color rendering index up to 80. MR16, GU10 base available, easy installation, with direct replacement of the traditional halogen.

- Up to 70% energy saving compared to halogen lamp
- Long lifetime of 40,000 hours
- 36° 60° beam angle
- Standard 50mm diameter
- CCT: 2700K 3000K 4000K 5000K
- No UV/IR light
- Environment friendly, without Mercury or any other hazardous substances

## Application notes

- IP20 for indoor use
- Professional electrician for installation only
- Switch off before installation
- Do not touch when in use
- Keep away from hot steam and corrosive gas

## Application Areas

Application: It is widely used in residential lighting, such as bedroom, living room dining room, kitchen etc. Also commercial lighting, like hotel, restaurant, bar, shops etc.

## Certificates



**RoHS**



# Product Information

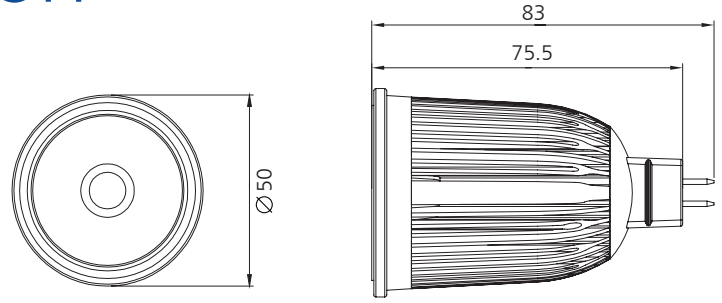

## Technical Specifications

Model	Voltage	Power	Power Factor	Lumen (±5%)	Beam angle	CCT	Lifespan	CRI	Dimmable	Dimension
UP-SP92MR16-9W	AC/DC 12V	9W	1	475	36° 60°	2700K	40000h	≥80	No	Ø50*83mm
UP-SP92MR16-9W	AC/DC 12V	9W	1	510	36° 60°	3000K	40000h	≥80	No	Ø50*83mm
UP-SP92MR16-9W	AC/DC 12V	9W	1	520	36° 60°	4000K	40000h	≥80	No	Ø50*83mm
UP-SP92MR16-9W	AC/DC 12V	9W	1	535	36° 60°	5000K	40000h	≥80	No	Ø50*83mm

## Driver data Sheet

Driver data	Non-dim
Input rated Voltage	AC/DC 12V
Frequency	50/60Hz
Input Voltage	AC/DC 12V
Efficiency	≥85%
Total load Wattage	9W±1W
Power Factor	1
Rated input current	≤0.75A
Full load output Voltage	DC35-37V
Rated output current	170mA
Output current range	170mA±5%
Power tolerance	±5%
Current output tolerance	±5%

## Fixture Compatibility

Rated Wattage	Electrical Classification	Ingress Protection	Operating Temp	Operating Humidity	Storage Temp
9W	III	IP20	-20°C~45°C	0~100%	-20°C~65°C

# Spectral Distribution

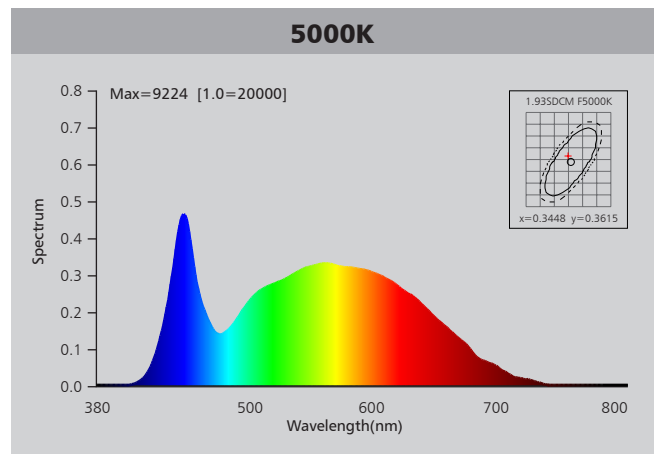
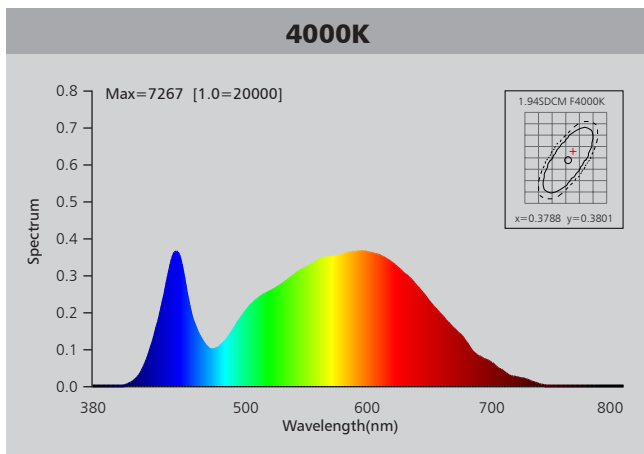
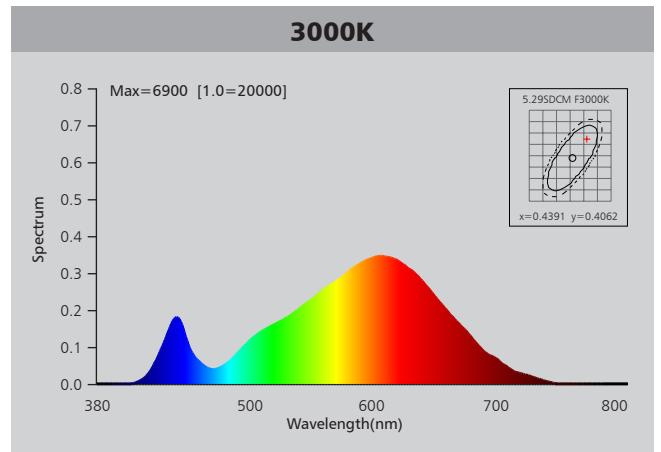
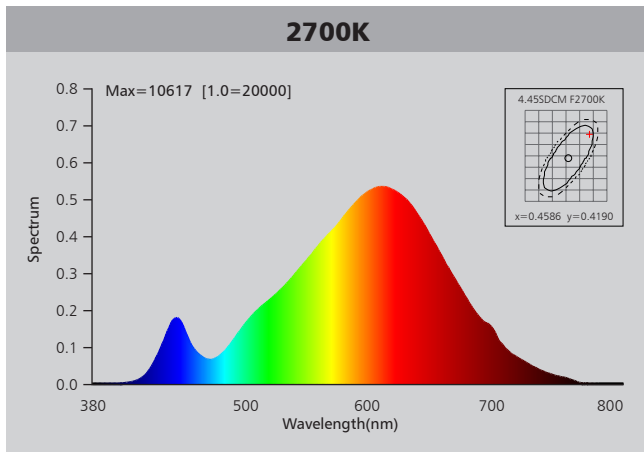

# Photometric Diagram

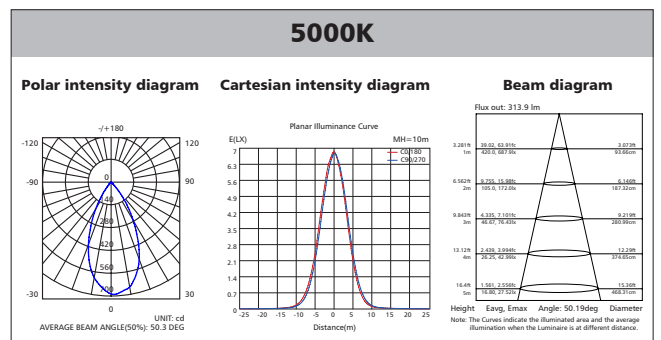
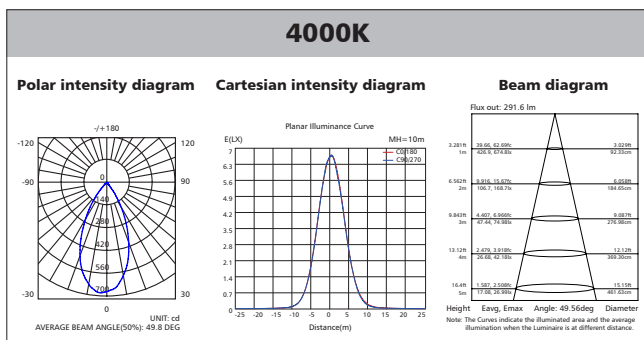
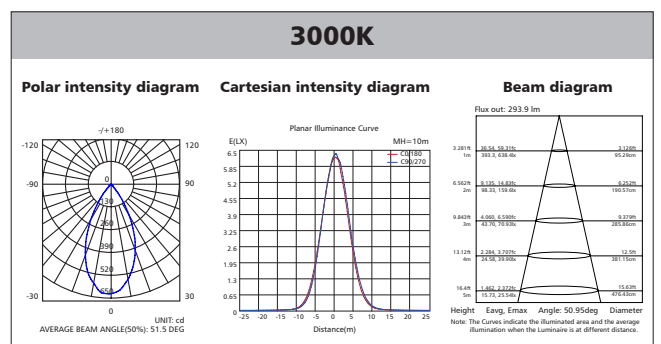
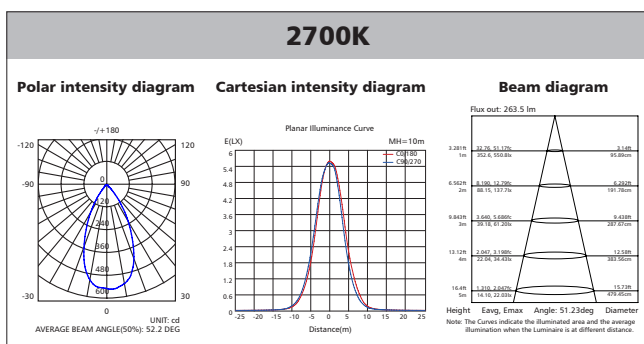

## Polar Diagram Comparison

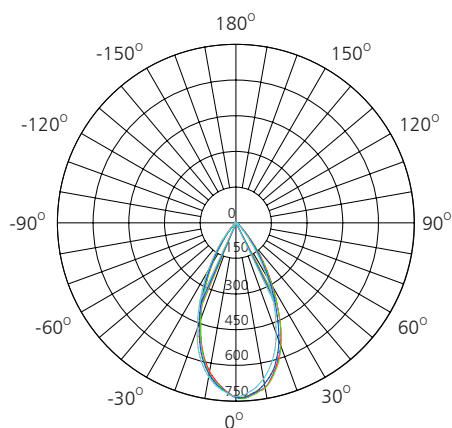

UNIT: cd

- C0/180, 50.3 deg
- C30/210, 50.3 deg
- C60/240, 50.2 deg
- C90/270, 50.3 deg

AVERAGE BEAM ANGLE (50%): 50.3 DEG



## Driver lifetime & LED light decay rate

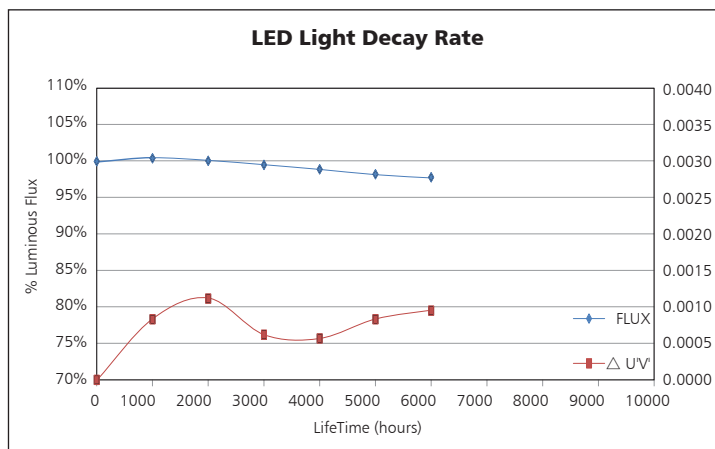
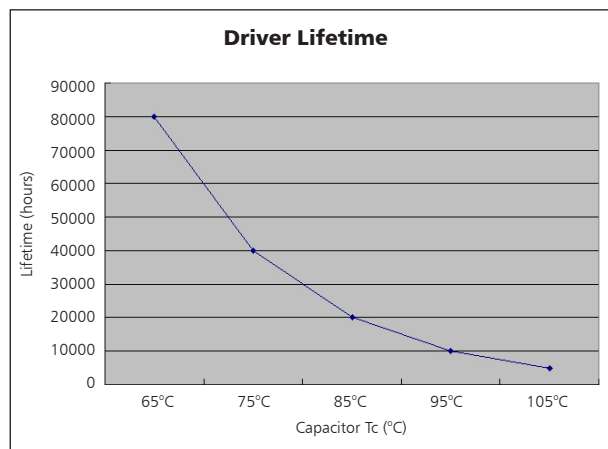

## Temperature

- The testing is operated at 25°C
- The lifetime of capacitor, minimum of 5,000 hours if operated at 105°C, will be doubled whenever the temperature drops 10°C
- The highest withstand temperature of IC, MOS could be 120°C
- The highest withstand temperature of LED junction temperature is 150°C

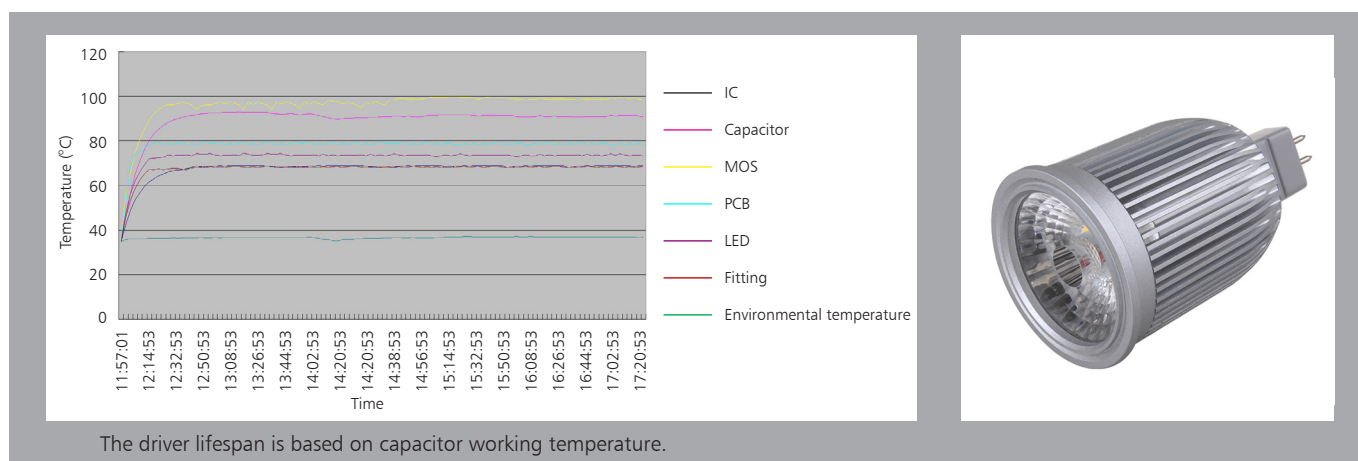

## Installation

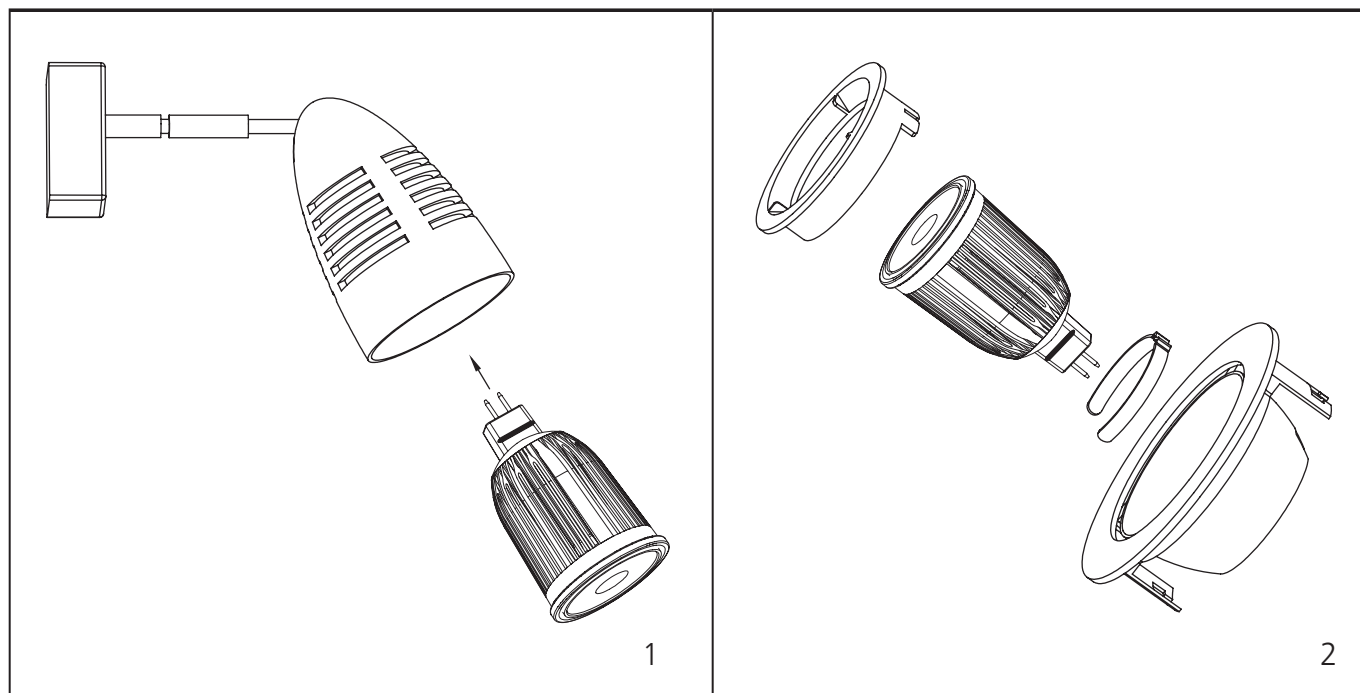

## Packaging Information

	SIZE(CM)	N.W/pc (KGS)	G.W.(KGS)	Q'TY(PCS)
Carton	29*29*47.5	0.105	14	100

	CTNS	Q'TY(PCS)	VOLUME(CBM)
20" standard container	700	70000	28
40" standard container	1400	140000	56

